



Selection: Semi-hermetic Screw Compressors HS

Input Values

Compressor model	HSN8591-160	Operating mode	Standard
Refrigerant	R507A	Power supply	400V-3-50Hz
Reference temperature	Dew point temp.	Useful superheat	100%
Liq. subc. (in condenser)	0 K	Additional cooling	Automatic
Suct. gas superheat	10/00 K	Max. discharge gas temp.	80/0 °C

Result

Q [W]	Cooling capacity	mHP [kg/h]	Mass flow HP
P [kW]	Power input	Qac [kW]	Additional cooling
I [A]	Current	tcu [°C]	Liquid temp.
COP [-]	COP/EER	pm [bar(a)]	ECO pressure
mLP [kg/h]	Mass flow LP	Qsc [kW]	sub cooler capacity (ECO)

tc	to	-10°C	-15°C	-20°C	-25°C	-30°C	-35°C	-40°C	-45°C
30°C	Q [W]	--	294878	239571	192688	153197	120161	92733	70144
	P [kW]	--	102/6	95/9	90/2	85/3	81/0	77/1	73/4
	I [A]	--	170/2	159/9	151/2	143/9	137/6	131/9	126/6
	COP [-]	--	2/87	2/50	2/14	1/80	1/48	1/20	0/96
	mLP [kg/h]	--	8931	7442	6146	5022	4054	3223	2514
	mHP [kg/h]	--	8931	7442	6146	5022	4054	3223	2514
	Qac [kW]	--	--	--	--	--	--	2/41	12/95
	tcu [°C]	--	30/0	30/0	30/0	30/0	30/0	30/0	30/0
	pm [bar(a)]	--	--	--	--	--	--	--	--
	Qsc [kW]	--	--	--	--	--	--	--	--
40°C	Q [W]	--	248225	200292	159799	125817	97504	74098	54913
	P [kW]	--	118/0	111/2	105/4	100/3	95/7	91/3	87/0
	I [A]	--	194/4	183/8	174/7	166/7	159/6	153/0	146/5
	COP [-]	--	2/10	1/80	1/52	1/25	1/02	0/81	0/63
	mLP [kg/h]	--	8689	7220	5940	4829	3870	3046	2342
	mHP [kg/h]	--	8689	7220	5940	4829	3870	3046	2342
	Qac [kW]	--	--	--	--	3/20	14/52	24/8	33/8
	tcu [°C]	--	40/0	40/0	40/0	40/0	40/0	40/0	40/0
	pm [bar(a)]	--	--	--	--	--	--	--	--
	Qsc [kW]	--	--	--	--	--	--	--	--
50°C	Q [W]	--	197788	157752	124065	95910	72550	53318	37614
	P [kW]	--	137/7	130/7	124/5	118/9	113/7	108/7	103/6
	I [A]	--	226	215	205	195/9	187/7	179/7	171/8
	COP [-]	--	1/44	1/21	1/00	0/81	0/64	0/49	0/36
	mLP [kg/h]	--	8332	6885	5620	4519	3563	2735	2020
	mHP [kg/h]	--	8332	6885	5620	4519	3563	2735	2020
	Qac [kW]	--	6/26	16/41	26/5	36/3	45/5	53/9	61/3
	tcu [°C]	--	50/0	50/0	50/0	50/0	50/0	50/0	50/0
	pm [bar(a)]	--	--	--	--	--	--	--	--
	Qsc [kW]	--	--	--	--	--	--	--	--

-- No calculation possible (see message in single point selection)

*According to EN12900 (10K suction gas superheat, 0K liquid subcooling)

Application Limits Standard HSN8591-160

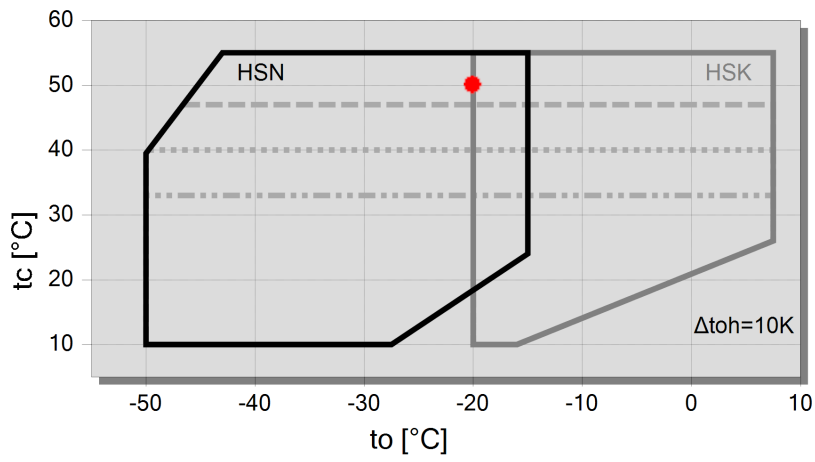

Legend

- max. tc for frequencies = 20Hz
- max. tc for frequencies = 25Hz
- max. tc for frequencies = 35Hz
- A



Technical Data: HSN8591-160

Dimensions and Connections

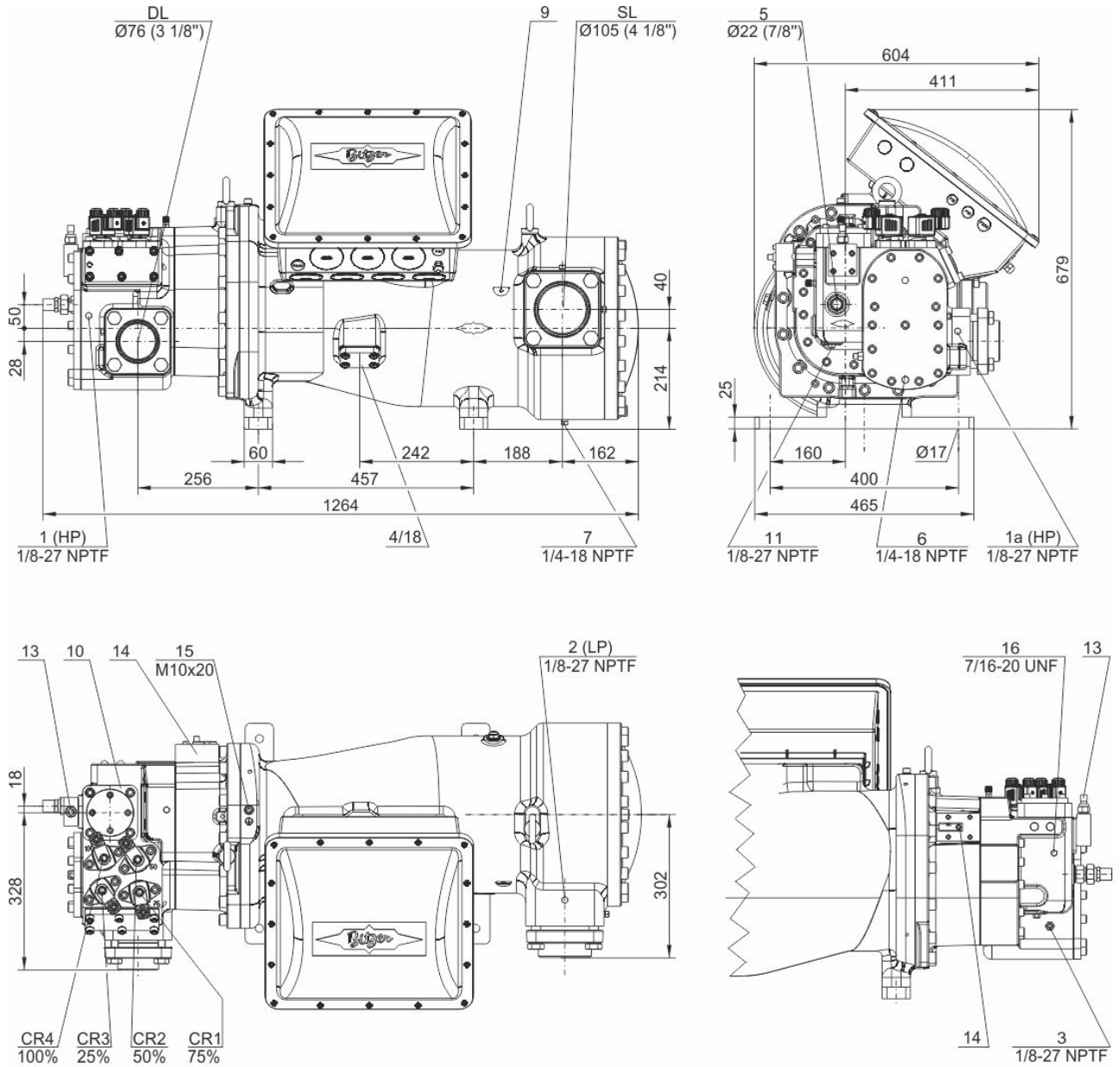



Technical Data

Technical Data

Displacement (2900 RPM 50 Hz)	535 m ³ /h
Displacement (3500 RPM 60 Hz)	646 m ³ /h
Weight	680 kg
Max. pressure (LP/HP)	19 / 28 bar
Connection suction line	DN 100
Connection discharge line	76 mm - 3 1/8"
Adapter/shut-off valve for ECO	28 mm - 1 1/8" (Option)
Oil type R22	B150SH, B100 (Option)
Oil type R134a/R404A/R507A/R407A/R407F	BSE170
Oil type R448A/R449A/R454C	BSE170

Motor data

Motor version	1
Motor voltage (more on request)	380-415V PW-3-50Hz
Max operating current	274.0 A
Starting current (Rotor locked)	729.0 A D / 1114.0 A DD
Max. Power input	175/0 kW

Extent of delivery (Standard)

Discharge gas temperature sensor	Standard
Start unloading	Standard
Oil flow control	SE-B3 (Standard)
Motor protection	SE-E1 + SE-B3 (Standard), SE-E3 (Standard for 660-690V)
Capacity control	100-75-50% or 100-50% (Standard)
Enclosure class	IP54

Available Options

Suction shut-off valve	Option
Discharge shut-off valve	Option
ECO connection with shut-off valve	Option
Motor protection	SE-i1 (200-690V)

Sound measurement



Semi-hermetic Screw Compressors HS

HSK = Application for air-conditioning and medium temperature cooling.

HSN = Application for low temperature cooling.

Notes regarding application limits (see "Limits")

- * Ranges are valid for standard operation and at full-load conditions.
- * With high pressure conditions, part-load operation is partly limited (see application limits in applications manual SH-100).
- * With Economizer operation the maximum admissible evaporation temperature is shifted by 10K downward (otherwise there is a danger of excessive compression and overload of the motor because of a higher mass flow). At pull-down conditions from higher evaporation temperatures, the ECO injection must remain closed until the evaporation temperature is below the maximum admissible value and a stable operation is achieved (e.g. control of the ECO solenoid valve by means of a low pressure cut-out). The use of the ECO-system with higher evaporation temperatures requires individual consultation with Bitzer.

HS 64/74

- * Capacity control with ECO operation at the same time is limited to one single regulating step (CR 75%). At CR 50% the ECO injection should be closed.

Data for sound emission

Data are based on 50Hz application (IP-units 60Hz) and R404A.

Sound pressure level: values are based on open air test sites with semi-spherical sound emissions at 1 meter distance. For further information see Technical Information "Sound Data".

Legend of connection positions according to "Dimensions":

- 1 High pressure connection (HP)
Connection for high pressure switch (HP)
- 1a Additional high pressure connection (HP)
Not suitable for pressure switch or pressure transmitter!
- 1b Connection for high pressure transmitter (HP)
- 2 Low pressure connection (LP)
Connection for low pressure switch
- 2a Additional low pressure connection (LP)
- 2b Connection for low pressure transmitter (LP)
- 2c Low pressure connection for the minimum pressure differential control valve
- 3 Connection for discharge gas temperature sensor (HP)
- 4 Connection for economiser (ECO)
HS.85: ECO valve with connection line (option)
OS.85, OS.95, OS.105, HS.95: ECO valve (option)
- 5 Connection/valve for oil injection
- 6 Oil pressure connection
- 7 Oil drain (compressor or motor housing)
- 7a Oil drain (suction gas filter)
- 7b Oil drain from shaft seal (maintenance connection)
- 7c Oil drain hose (shaft seal)
- 8 Threaded bore for foot fastening
- 9 Threaded bore for pipe fixture (ECO and LI lines)
- 10 Maintenance connection for oil filter
- 11 Oil drain (oil filter)
- 13 Oil filter monitoring
- 14 Oil flow switch
- 15 Earth screw for housing
- 16 Pressure blow-off (oil filter chamber)
- 17 Maintenance connection for shaft seal
- 18 Liquid injection (LI)
- 19 Compressor module
- 20 Slider position indicator
- 21 Oil level switch
- 22 Oil pressure transmitter



- 23 Connection for oil and gas return (for systems with flooded evaporator adaptor optional)
- 24 Access to oil circulation restrictor
- 25 Oil inlet for shaft seal cooling
- 26 Oil outlet for shaft seal cooling
- 27 Temperature sensor in the shaft seal
- 28 Vibration sensor connection
- SL Suction gas line
- DL Discharge gas line

Dimensions can show tolerances according to EN ISO 13920-B.