



Selection: Semi-hermetic Screw Compressors HS

Input Values

Compressor model	HSK8551-110	Operating mode	Standard
Refrigerant	R507A	Power supply	400V-3-50Hz
Reference temperature	Dew point temp.	Useful superheat	100%
Liq. subc. (in condenser)	0 K	Additional cooling	Automatic
Suct. gas superheat	10/00 K	Max. discharge gas temp.	80/0 °C

Result

Q [W]	Cooling capacity	mHP [kg/h]	Mass flow HP
P [kW]	Power input	Qac [kW]	Additional cooling
I [A]	Current	t _{cu} [°C]	Liquid temp.
COP [-]	COP/EER	pm [bar(a)]	ECO pressure
mLP [kg/h]	Mass flow LP	Qsc [kW]	sub cooler capacity (ECO)

tc	to	5°C	2°C	-1°C	-4°C	-7°C	-10°C	-13°C	-16°C
30°C	Q [W]	383967	344584	308488	275454	245267	217731	192654	169865
	P [kW]	68/7	67/8	67/0	66/1	65/2	64/3	63/5	62/8
	I [A]	116/8	115/5	114/2	112/9	111/6	110/4	109/2	108/2
	COP [-]	5/59	5/08	4/61	4/17	3/76	3/39	3/03	2/71
	mLP [kg/h]	10621	9652	8753	7920	7149	6436	5778	5170
	mHP [kg/h]	10621	9652	8753	7920	7149	6436	5778	5170
	Qac [kW]	--	--	--	--	--	--	--	--
	t _{cu} [°C]	30/0	30/0	30/0	30/0	30/0	30/0	30/0	30/0
	pm [bar(a)]	--	--	--	--	--	--	--	--
	Qsc [kW]	--	--	--	--	--	--	--	--
40°C	Q [W]	330829	295764	263689	234393	207682	183376	161297	141289
	P [kW]	82/6	81/7	80/9	80/1	79/3	78/6	77/9	77/3
	I [A]	137/3	136/0	134/8	133/6	132/4	131/3	130/4	129/5
	COP [-]	4/01	3/62	3/26	2/93	2/62	2/33	2/07	1/83
	mLP [kg/h]	10435	9464	8563	7729	6956	6242	5583	4974
	mHP [kg/h]	10435	9464	8563	7729	6956	6242	5583	4974
	Qac [kW]	--	--	--	--	--	--	--	--
	t _{cu} [°C]	40/0	40/0	40/0	40/0	40/0	40/0	40/0	40/0
	pm [bar(a)]	--	--	--	--	--	--	--	--
	Qsc [kW]	--	--	--	--	--	--	--	--
50°C	Q [W]	272936	242490	214726	189455	166499	145693	126877	109907
	P [kW]	100/8	100/1	99/4	98/8	98/2	97/6	97/2	96/8
	I [A]	164/7	163/6	162/6	161/6	160/7	159/9	159/2	158/6
	COP [-]	2/71	2/42	2/16	1/92	1/70	1/49	1/31	1/14
	mLP [kg/h]	10156	9177	8270	7430	6653	5935	5272	4662
	mHP [kg/h]	10156	9177	8270	7430	6653	5935	5272	4662
	Qac [kW]	--	--	--	--	1/83	8/85	15/74	22/5
	t _{cu} [°C]	50/0	50/0	50/0	50/0	50/0	50/0	50/0	50/0
	pm [bar(a)]	--	--	--	--	--	--	--	--
	Qsc [kW]	--	--	--	--	--	--	--	--

-- No calculation possible (see message in single point selection)

*According to EN12900 (10K suction gas superheat, 0K liquid subcooling)

Application Limits Standard HSK8551-110

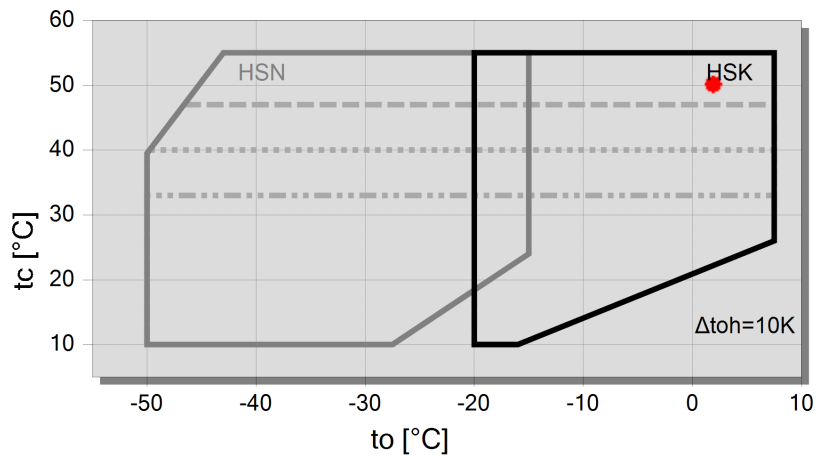

Legend

- max. tc for frequencies = 20Hz
- ... max. tc for frequencies = 25Hz
- max. tc for frequencies = 35Hz
- A



Technical Data: HSK8551-110

Dimensions and Connections

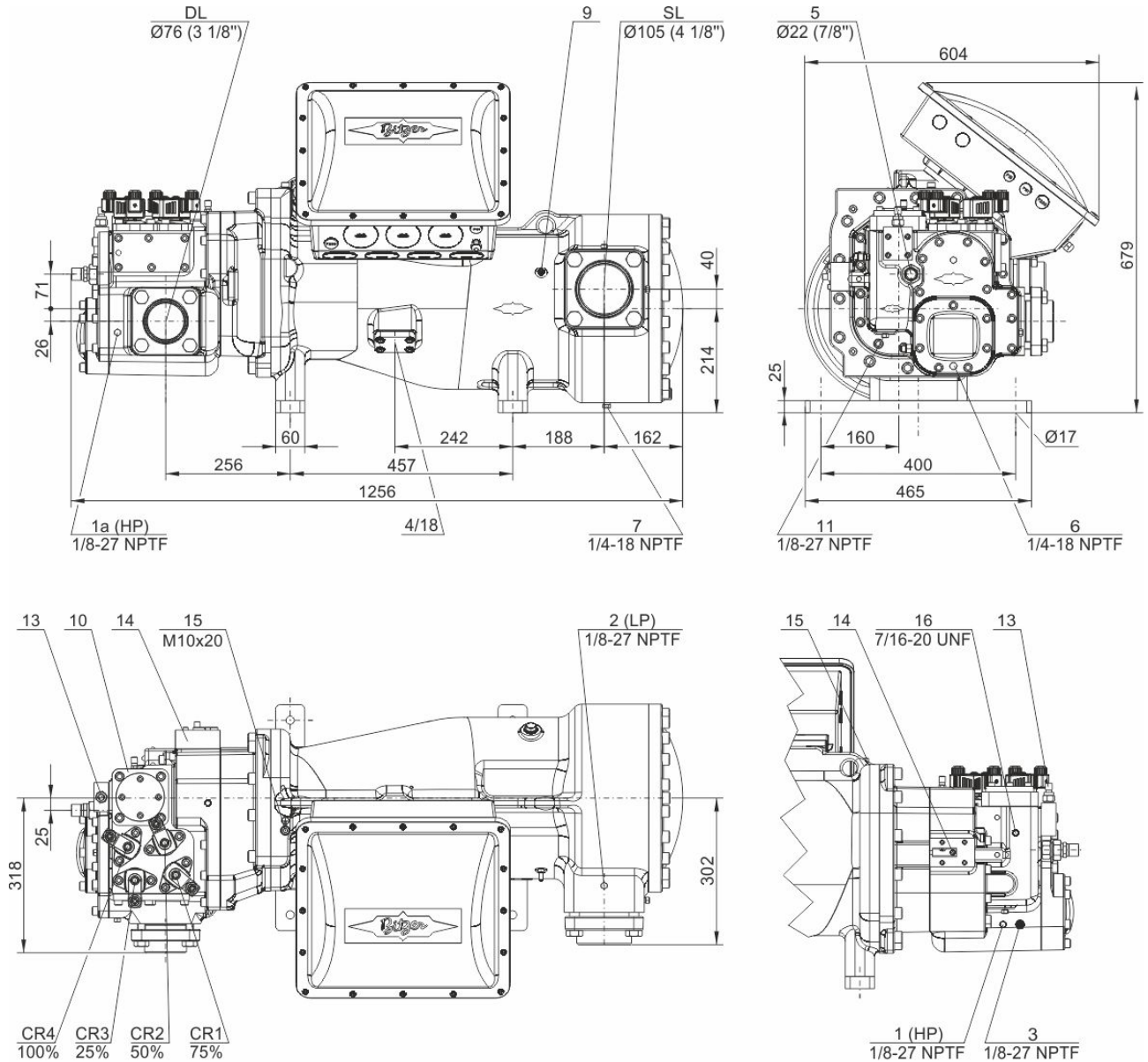



Technical Data

Technical Data

Displacement (2900 RPM 50 Hz)	315 m ³ /h
Displacement (3500 RPM 60 Hz)	380 m ³ /h
Weight	565 kg
Max. pressure (LP/HP)	19 / 28 bar
Connection suction line	DN 100
Connection discharge line	76 mm - 3 1/8"
Adapter/shut-off valve for ECO	28 mm - 1 1/8" (Option)
Adapter for liquid injection	22 mm - 7/8" (Option)
Oil type R22	B150SH, B100 (Option)
Oil type R134a/R404A/R507A/R407A/R407F	BSE170
Oil type R448A/R449A/R454C	BSE170

Motor data

Motor version	1
Motor voltage (more on request)	380-415V PW-3-50Hz
Max operating current	180.0 A
Starting current (Rotor locked)	520.0 A D / 801.0 A DD
Max. Power input	110/0 kW

Extent of delivery (Standard)

Discharge gas temperature sensor	Standard
Start unloading	Standard
Oil flow control	SE-B3 (Standard)
Motor protection	SE-E1 + SE-B3 (Standard), SE-E3 (Standard for 660-690V)
Capacity control	100-75-50% or 100-50% (Standard)
Enclosure class	IP54

Available Options

Suction shut-off valve	Option
Discharge shut-off valve	Option
ECO connection with shut-off valve	Option
Motor protection	SE-i1 (200-690V)

Sound measurement



Semi-hermetic Screw Compressors HS

HSK = Application for air-conditioning and medium temperature cooling.

HSN = Application for low temperature cooling.

Notes regarding application limits (see "Limits")

- * Ranges are valid for standard operation and at full-load conditions.
- * With high pressure conditions, part-load operation is partly limited (see application limits in applications manual SH-100).
- * With Economizer operation the maximum admissible evaporation temperature is shifted by 10K downward (otherwise there is a danger of excessive compression and overload of the motor because of a higher mass flow). At pull-down conditions from higher evaporation temperatures, the ECO injection must remain closed until the evaporation temperature is below the maximum admissible value and a stable operation is achieved (e.g. control of the ECO solenoid valve by means of a low pressure cut-out). The use of the ECO-system with higher evaporation temperatures requires individual consultation with Bitzer.

HS 64/74

- * Capacity control with ECO operation at the same time is limited to one single regulating step (CR 75%). At CR 50% the ECO injection should be closed.

Data for sound emission

Data are based on 50Hz application (IP-units 60Hz) and R404A.

Sound pressure level: values are based on open air test sites with semi-spherical sound emissions at 1 meter distance. For further information see Technical Information "Sound Data".

Legend of connection positions according to "Dimensions":

- 1 High pressure connection (HP)
Connection for high pressure switch (HP)
- 1a Additional high pressure connection (HP)
Not suitable for pressure switch or pressure transmitter!
- 1b Connection for high pressure transmitter (HP)
- 2 Low pressure connection (LP)
Connection for low pressure switch
- 2a Additional low pressure connection (LP)
- 2b Connection for low pressure transmitter (LP)
- 2c Low pressure connection for the minimum pressure differential control valve
- 3 Connection for discharge gas temperature sensor (HP)
- 4 Connection for economiser (ECO)
HS.85: ECO valve with connection line (option)
OS.85, OS.95, OS.105, HS.95: ECO valve (option)
- 5 Connection/valve for oil injection
- 6 Oil pressure connection
- 7 Oil drain (compressor or motor housing)
- 7a Oil drain (suction gas filter)
- 7b Oil drain from shaft seal (maintenance connection)
- 7c Oil drain hose (shaft seal)
- 8 Threaded bore for foot fastening
- 9 Threaded bore for pipe fixture (ECO and LI lines)
- 10 Maintenance connection for oil filter
- 11 Oil drain (oil filter)
- 13 Oil filter monitoring
- 14 Oil flow switch
- 15 Earth screw for housing
- 16 Pressure blow-off (oil filter chamber)
- 17 Maintenance connection for shaft seal
- 18 Liquid injection (LI)
- 19 Compressor module
- 20 Slider position indicator
- 21 Oil level switch
- 22 Oil pressure transmitter



- 23 Connection for oil and gas return (for systems with flooded evaporator adaptor optional)
- 24 Access to oil circulation restrictor
- 25 Oil inlet for shaft seal cooling
- 26 Oil outlet for shaft seal cooling
- 27 Temperature sensor in the shaft seal
- 28 Vibration sensor connection
- SL Suction gas line
- DL Discharge gas line

Dimensions can show tolerances according to EN ISO 13920-B.